

S4-1-G CENTRIFUGE

The S4-1-G Centrifuge is a very large high-speed decanting centrifuge made with high strength carbon steel parts and ceramic protection on the tips of the scroll. The centrifuge has a 900mm diameter 2700mm long bowl with variable speed drive, powered by a 75kW motor with inverter control, running on two main bearings with pumped oil lubrication. The centrifuge is carried on a base frame fitted with anti-vibration rubber pads. The machine is equipped with a variable speed twin start 300mm pitch scroll, driven by a heavy duty mechanical gearbox, powered by a 30kW electric motor with inverter speed control. This enables the centrifuge to be used for many applications ranging from de-sanding of drilling fluids through silt removal to waste fluid clean-up using forced de-watering of flocculated solids.

The S4-1-G consists of two modules, each 6058x2438x2591mm high being the size of a standard 20 foot, type 1CC freight container, complete with twistlock corners. In operation the centrifuge module mounts on top of the powerhouse module, so that the complete machine requires a working footprint of 8.2m x 3.0m and stands 5.2m high. The S4-1-G is fed by a variable speed feed pump system. The rate of fluid feed to the centrifuge is controlled by altering the speed of the feed pump(s).

The centrifuge module has a heavy duty hollow section frame into which are mounted the S4 decanting centrifuge, 75kW electric motor for the bowl drive, 30kW scroll drive motor and electrical controls. A solids discharge chute with retractable diverter plate and centrate discharge chute with discharge pipe. Normally the separated solids would discharge on to the ground beneath the centrifuge module at one end of the tank module for removal by back-hoe or front-end loader or would discharge into a skip, positioned beneath the centrifuge module. Alternatively the solids could discharge onto a separate conveyor system.

The power house module houses a tank for storage of the centrate and a control room containing the electrical control panels, switchgear and inverters for the operation of the centrifuge and pumps. A supply isolation transformer with air circulation fan and air conditioning can be provided. A Metso HM100 pump with 22kW motor and inverter speed control is sited within this module and is used for the discharge of the centrate.

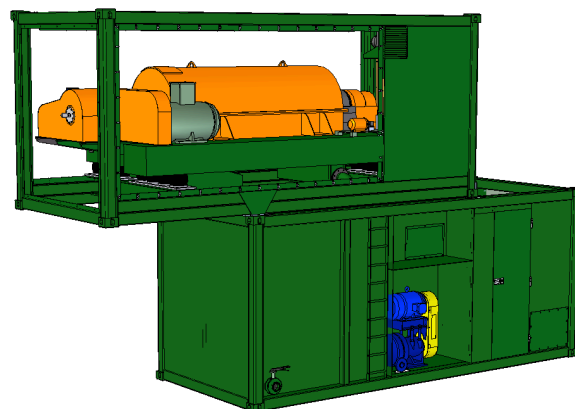

TECHNICAL DATA:

Centrifuge module: Dimensions: 6058x2438x2591mm high.
Weight: 16 tonnes.
Power: 105 kW.

Pump tank module: Dimensions: 6058x2438x2591mm high.
Weight: 8 tonnes empty.
Power: 44kW.

In operation: Footprint: 8.2m x 3.0m
Weight: 26 to 40 tonnes depending on volume in tank.

Process capacity: Up to 75m³/hr of ideal fluids but typically up to 50m³/hr of drilling fluids with silts or up to 30m³/hr with flocculated clay contaminated drilling fluids.

Solids removal rate: Up to 12 tonnes/hr of easily separated solids but typically up to 8 tonnes/hr of silts or 6 tonnes/hr of flocculated solids.

G force: Up to 720 'G'.

Power requirements: The unit requires a 415V, 3-phase and earth, 50Hz electrical supply, no neutral is required. Starting current for the unit is 400A, full load current is 300A per phase. A 225KVA generator would normally be required to run the S4-1-G Centrifuge.

Solids discharge: At one end of the tank module beneath the centrifuge module.

Fluid discharge: By Metso HM100 inverter controlled pump, through a 3" or 4" Bauer fitting.